

FF425 NON-CONTACT FLANGED TORQUE TRANSDUCER PRODUCT OVERVIEW

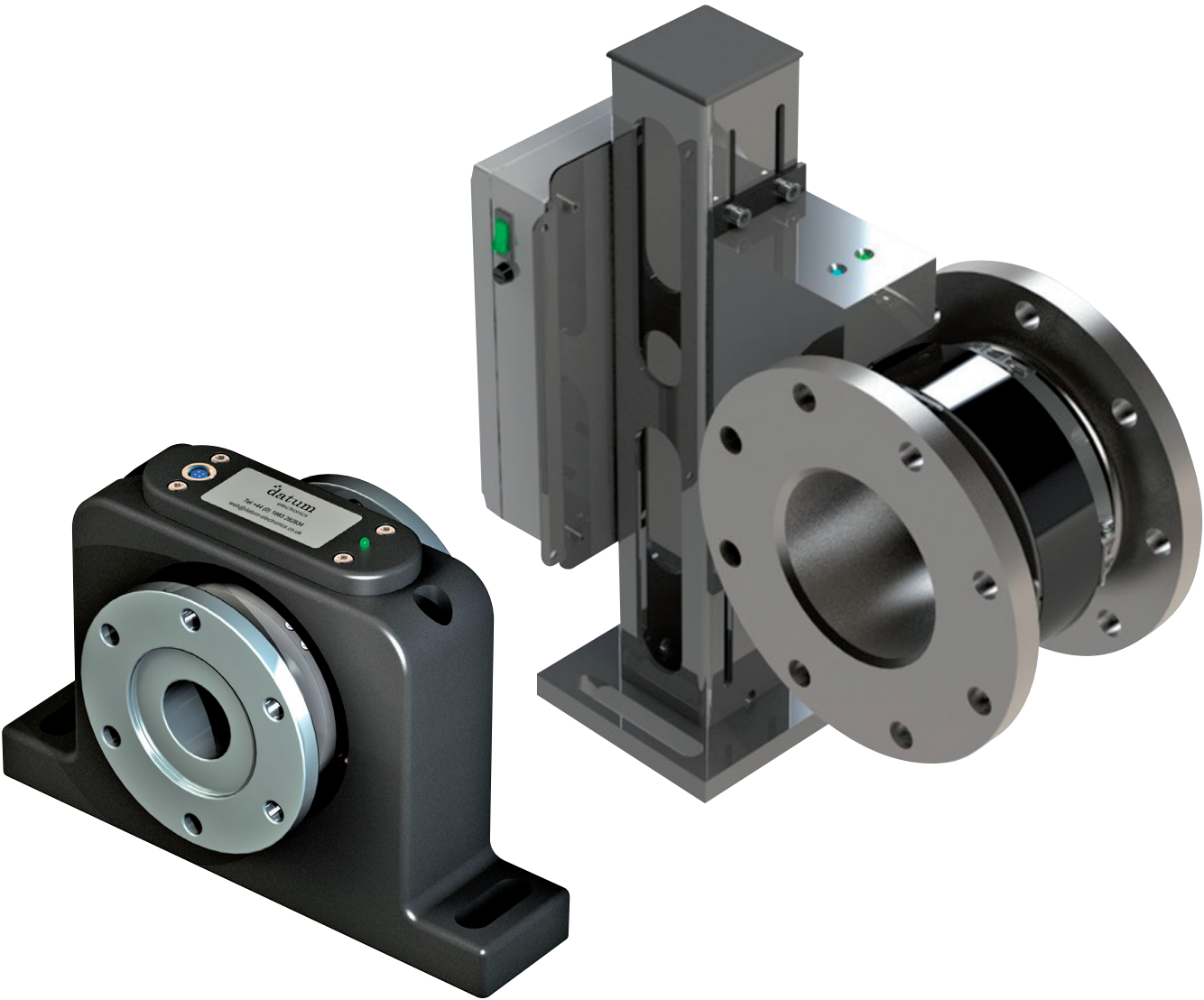

vetec

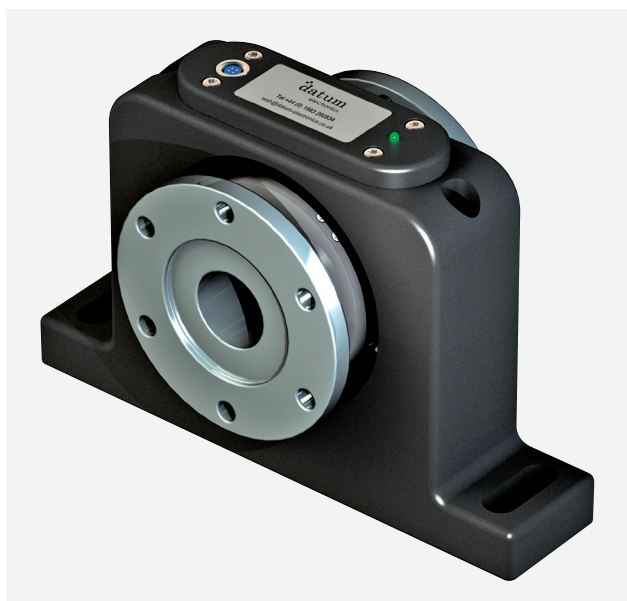

THE FF425 NON-CONTACT FLANGED TORQUE TRANSDUCER

Using the latest technology the Series FF425 non-contact rotary Flanged Torque Transducers fit directly as replacement drive line spacers and couplings. The transducer utilises the 425 Series state of the art electronics, offering very high accuracy, operational stability, high signal resolution and a wide range of signal output options.

The Torque Transducer can either be supplied from our standard range with DIN flanges up to 30KNm or as custom units up to any size with the flange and length dimension designed to fit an existing coupling spacer design. With the custom option drive lines can have a torque transducer integrated with a minimum of cost and disruption or need to find additional space.

The FF425 is a true non-contact torque transducer, the rotor runs inside the stator with a 2 to 5mm air gap. This ensures no long-term wear of bearings or frictional loads on the rotating drive shaft.

The FF425 Torque Transducers are ideal for test rigs and permanent machinery applications.

FF425 SYSTEM PERFORMANCE AND BENEFITS:

Ranges from 0-100Nm up to 30KNm as standard

For larger ranges up to any size, please contact us

High Accuracy

High Torque Resolution

Fully Non-Contact Transmission and Hardware

Can be Supplied Custom to Your Driveline

Fast Data Sampling Rates

Robust Construction

Low Power Consumption

SPECIFICATIONS

FF425 PERFORMANCE INFORMATION

PERFORMANCE

Non-Linearity	+/-0.1% FSD
Non-Repeatability	+/-0.05% FSD
Noise-free Resolution	20 bit to 13.5 bit (dependent on sample rate)
Sample Rate	1 to 4000 samples per second
Output Baud Rate	9600 to 3Mbaud

Transducer output:

Serial data via RS485 see Datum Universal Interface Specification for standard options including 4-20mA, +/-10Vdc, Ethernet, RS485, USB.

Transducer output data:

Torque	Shaft RPM*	Shaft Temp.	Diagnostics
--------	------------	-------------	-------------

*Output of RPM based on 1 input pulse per revolution as standard

POWER SUPPLY

Transducer	10-24Vdc 250mA
Transducer and Interface	15-24Vdc 400mA

ENVIRONMENT

Thermal Stability of Gain per 10°C	0.02%
Thermal Stability of Zero per 10°C	0.02%
Normal Specification Range	10 to 60°C
Operating Range	-10 to +70°C
Storage Range	-35 to +75°C
Environmental Protection	IP54 (or IP67 with Option ET)
Electromagnetic Compatibility	EN61326-1:2006 (IEC61000-4), IEC60945)

FOR SIGNAL OUTPUT OPTIONS INCLUDING:

Ethernet, MODBUS, USB, RS485/232 and 4 analogue channels configured 4-20mA (4-12-20mA): +/-10Vdc, +/-5Vdc, 0-10Vdc or 0-5Vdc, refer to Document 1023 Datum Universal Transducer Interface.

SPECIFICATIONS FF425 dimensions (mm)

FF425 Model Size	Rated load (Nm)	Rated load (lb ft)	Standard Rotational speed (RPM)	Body mass (Kgs)	Rotor mass (Kgs)	A Shaft length face to face (mm)	B Body width (mm)	C Flange Ø (mm)	D Male/Female flange coupling extrusion/depth (mm)	E Male/Female flange coupling Ø H7/h6 TOL (mm) (ISO 286)	F Flange thickness (mm)	G Number of holes	H PCD (mm)	I Hole Specification (ISO 4017 / DIN 933 / ISO 273)	J Base to shaft centre (mm)	K Output module length (mm)	L Output module height (mm)	M Base length (mm)	N Overall height (mm)	O Base fixing slot. Centre to centre (mm)	P Fixing slot length (mm)	Q Slot width (mm)
Size 1	0-100	73.8	10,000	1.057	0.560	97.5	50	100	2.5	57	8	6	84	M8	80	112	8.5	220	143.5	188	22	13
Size 2 - A	0-250	184	10,000	1.057	1.201	97.5	50	100	2.5	57	8	6	84	M8	80	112	8.5	220	143.5	188	22	13
Size 2 - B	0-500	369	10,000	1.057	1.276	97.5	50	100	2.5	57	8	6	84	M8	80	112	8.5	220	143.5	188	22	13
Size 3 - A	0-1000	738	10,000	1.057	1.668	97.5	50	120	2.5	75	8	8	155.5	M10	80	112	8.5	220	143.5	188	22	13
Size 3 - B	0-2000	1475.1	10,000	1.057	2.149	107.5	50	120	2.5	75	8	8	155.5	M10	80	112	8.5	220	143.5	188	22	13
Size 4 - A	0-5000	3687.9	8000	1.152	6.112	137	50	180	3	110	12	8	155.5	M14	100	112	8.5	220	172.5	188	22	13
Size 4 - B	0-10,000	7375.7	8000	1.152	12.162	157	60	185	3	110	15	8	155.5	M14	100	112	8.5	220	172.5	188	22	13
Size 5 - A	0-15,000	11064	6000	2.138	20.499	216	60	250	5.5	140	20	8	217	M16	100	112	8.5	300	212.5	266	22	13
Size 5 - B	0-20,000	14751	6000	2.138	22.318	216	60	250	5.5	140	20	8	217	M16	100	112	8.5	300	212.5	266	22	13
Size 5 - C	0-25,000	18439	6000	2.138	34.608	216	60	285	6	175	20	8	247	M18	100	112	8.5	300	212.5	266	22	13
Size 5 - D	0-30,000	22127	6000	2.138	40.969	216	60	315	6	190	22	8	275	M20	100	112	8.5	300	212.5	266	22	13

Alphabet key for FF425 model sizes 1 to 5

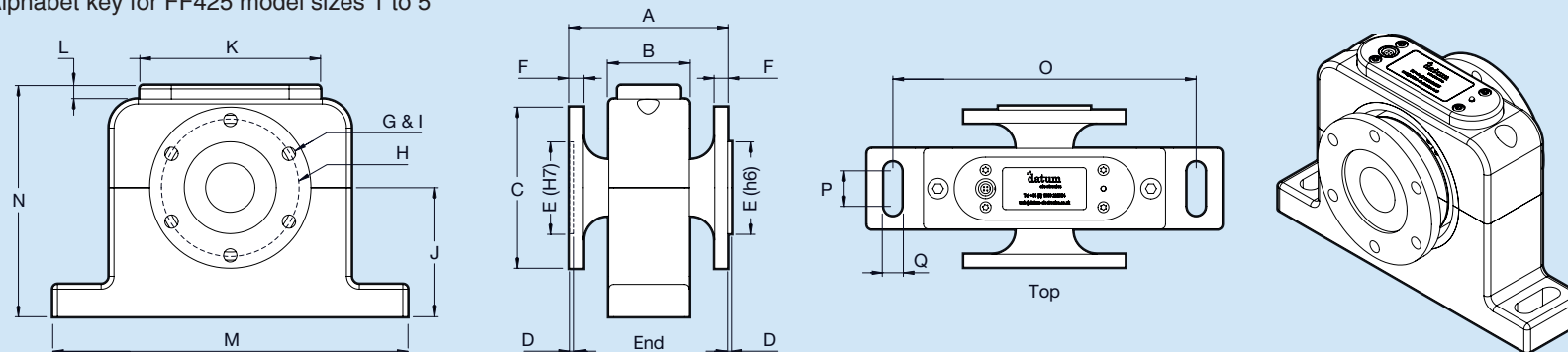

3D models and STEP files are available to assist project planning.